

Bolted Mechanical fittings

Standard series

Flanged Tee

Plain End to Flange

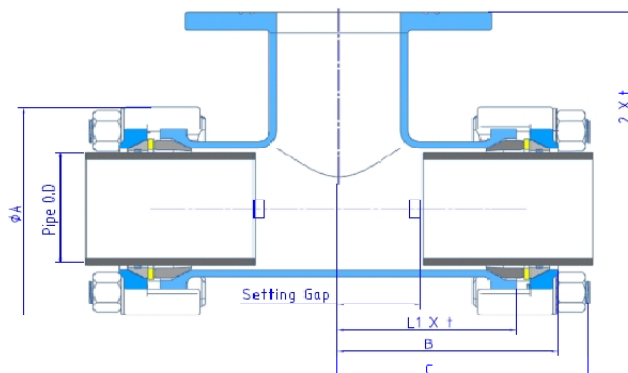

Main Dimensions

Unit: mm

Size	Pipe O.D.		Fitting Overall			Body			Setting Gap		Weight
	SGP-PD *	HIVP * *	A	B	C	L1	L2	t	Min	Max	Kg
80X50F	93.1	89	182	117	132	85	150	5	41	51	8.6
80X80F	93.1	89	182	124	139	92	153	5	48	58	10.1
80X100F	93.1	89	182	141	156	109	155	5	65	75	12.3
100X50F	118.3	114	219	134	139	95	180	6	40	56	11.9
100X80F	118.3	114	219	147	152	108	181	6	53	69	14.6
100X100F	118.3	114	219	155	160	116	185	6	61	77	16.1
Size	Bolts										
	n	M x L									
80X50F	3	M18x76									
80X80F	3	M18x76									
80X100F	3	M18x76									
100X50F	3	M18x76									
100X80F	3	M18x76									
100X100F	3	M18x76									

* JWWA K 132: Polyethylene powder-coated steel pipe for water supply.

* * JIS K 6742: Unplasticized poly (vinyl chloride) (PVC-U) pipes for water supply or other Imperial pipes including PVC pipe, PE Pipe, ABS pipe and Steel pipe.

When ordering, please notice flange Specification PN10/PN16 or JIS 10K



Qingdao Rockpower Machinery Co., Ltd.

1506, Sino-Commerce Building, 100, Middle Hongkong Road, Qingdao, China
www.rockpower.cn

Tel.: (0532) 8592-1910 8592-1920 Fax.: (0532) 8592-1252
 e-mail: rockson@rockpower.cn